

User Manual

Version 1.0 March 2014

OCD 300



Copyright 2014
All Rights Reserved
Manual Version 1.0

The information contained in this document is subject to change without notice. We make no warranty of any kind with regard to this material, including, but not limited to, the implied warranties of merchantability and fitness for a particular purpose. We shall not be liable for errors contained herein or for incidental or consequential damages in connection with the furnishing, performance, or use of this material.

This document contains proprietary information that is protected by copyright. All rights are reserved. No part of this document may be photocopied, reproduced or translated to another language without the prior written consent of the manufacturer.

TRADEMARK

Intel®, Pentium® and MMX are registered trademarks of Intel® Corporation. Microsoft® and Windows® are registered trademarks of Microsoft Corporation. Other trademarks mentioned herein are the property of their respective owners.

Safety

IMPORTANT SAFETY INSTRUCTIONS

1. To disconnect the machine from the electrical Power Supply, turn off the power switch and remove the power cord plug from the wall socket. The wall socket must be easily accessible and in close proximity to the machine.
2. Read these instructions carefully. Save these instructions for future reference.
3. Follow all warnings and instructions marked on the product.
4. Do not use this product near water.
5. Do not place this product on an unstable cart, stand, or table. The product may fall, causing serious damage to the product.
6. Slots and openings in the cabinet and the back or bottom are provided for ventilation; to ensure reliable operation of the product and to protect it from overheating. These openings must not be blocked or covered. The openings should never be blocked by placing the product on a bed, sofa, rug, or other similar surface. This product should never be placed near or over a radiator or heat register, or in a built-in installation unless proper ventilation is provided.
7. This product should be operated from the type of power indicated on the marking label. If you are not sure of the type of power available, consult your dealer or local power company.
8. Do not allow anything to rest on the power cord. Do not locate this product where persons will walk on the cord.
9. Never push objects of any kind into this product through cabinet slots as they may touch dangerous voltage points or short out parts that could result in a fire or electric shock. Never spill liquid of any kind on the product.



CE MARK

This device complies with the requirements of the EEC directive 2004/108/EC with regard to “Electromagnetic compatibility” and 2006/95/EC “Low Voltage Directive”



FCC

This device complies with part 15 of the FCC rules. Operation is subject to the following two conditions:

- (1) This device may not cause harmful interference.
- (2) This device must accept any interference received, including interference that may cause undesired operation

CAUTION ON LITHIUM BATTERIES

There is a danger of explosion if the battery is replaced incorrectly. Replace only with the same or equivalent type recommended by the manufacturer. Discard used batteries according to the manufacturer's instructions.



Battery Caution

Risk of explosion if battery is replaced by an incorrectly type.
Dispose of used battery according to the local disposal instructions.



Safety Caution

Note: To comply with IEC60950-1 Clause 2.5 (limited power sources, L.P.S) related legislation, peripherals shall be 4.7.3.2 "Materials for fire enclosure" compliant.

4.7.3.2 Materials for fire enclosures

For MOVABLE EQUIPMENT having a total mass not exceeding 18kg, the material of a FIRE ENCLOSURE, in the thinnest significant wall thickness used, shall be of V-1 CLASS MATERIAL or shall pass the test of Clause A.2.

For MOVABLE EQUIPMENT having a total mass exceeding 18kg and for all STATIONARY EQUIPMENT, the material of a FIRE ENCLOSURE, in the thinnest significant wall thickness used, shall be of 5VB CLASS MATERIAL or shall pass the test of Clause A.1

LEGISLATION AND WEEE SYMBOL

2012/19/EU Waste Electrical and Electronic Equipment Directive on the treatment, collection, recycling and disposal of electric and electronic devices and their components.



The crossed dustbin symbol on the device means that it should not be disposed of with other household wastes at the end of its working life. Instead, the device should be taken to the waste collection centers for activation of the treatment, collection, recycling and disposal procedure.

To prevent possible harm to the environment or human health from uncontrolled waste disposal, please separate this from other types of wastes and recycle it responsibly to promote the sustainable reuse of material resources.

Household users should contact either the retailer where they purchased this product, or their local government office, for details of where and how they can take this item for environmentally safe recycling.

Business users should contact their supplier and check the terms and conditions of the purchase contract.

This product should not be mixed with other commercial wastes for disposal.

Revision History

Revision	Date	Description
V1.0	March, 2014	● Release

Table of Contents

1 Item Checklist	6
2 System View & Dimension	6
3 Features	7
4 Specification	8
5 Interface	9
5-1 Connector Pin Definition.....	9
6 Driver Installation	10
7 Software Status Setting Commands	11
7-1 Baud Rate Setting Command.....	11
7-2 Parity Check Setting Command.....	11
7-3 Data Length Setting Command.....	11
7-4 International Character Set Setting Command.....	12
7-5 Select International Character Set Command	13
7-6 Select Character Code Table Command.....	13
7-7 Command Type Setting Command.....	14
7-8 Run Demo message.....	14
7-9 Show Firmware Version	14
7-10 Graphic LCM Contrast Setting.....	14
7-11 Display Logo Command	14
8 Command List Table	15
9 Command Details	17
9-1 POS7300 Series Command List	17
9-2 CD5220 Standard Mode Command List.....	20
9-3 UTC Standard Mode Command List.....	22
9-4 UTC Enhanced Mode Command List	22
9-5 AEDEX/EMAX Mode Command List.....	22
9-6 ADM787/788 mode command list.....	23
9-7 DSP800 Mode Command List.....	24
9-8 EPSON ESC/POS Command List.....	25
10 Character Set	27
10-1 Character Code 20H – 7FH	27
10-2 Character Code 80H – FFH	28
Appendix A: Command Details	36
Appendix B: Control Code Set	38

1 Item Checklist

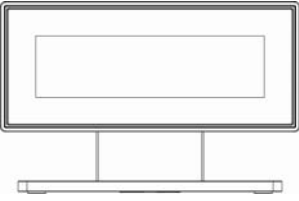
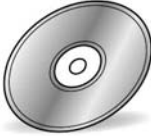
	
a. Customer Display with USB cable attached	b. Manual CD

2 System View & Dimension

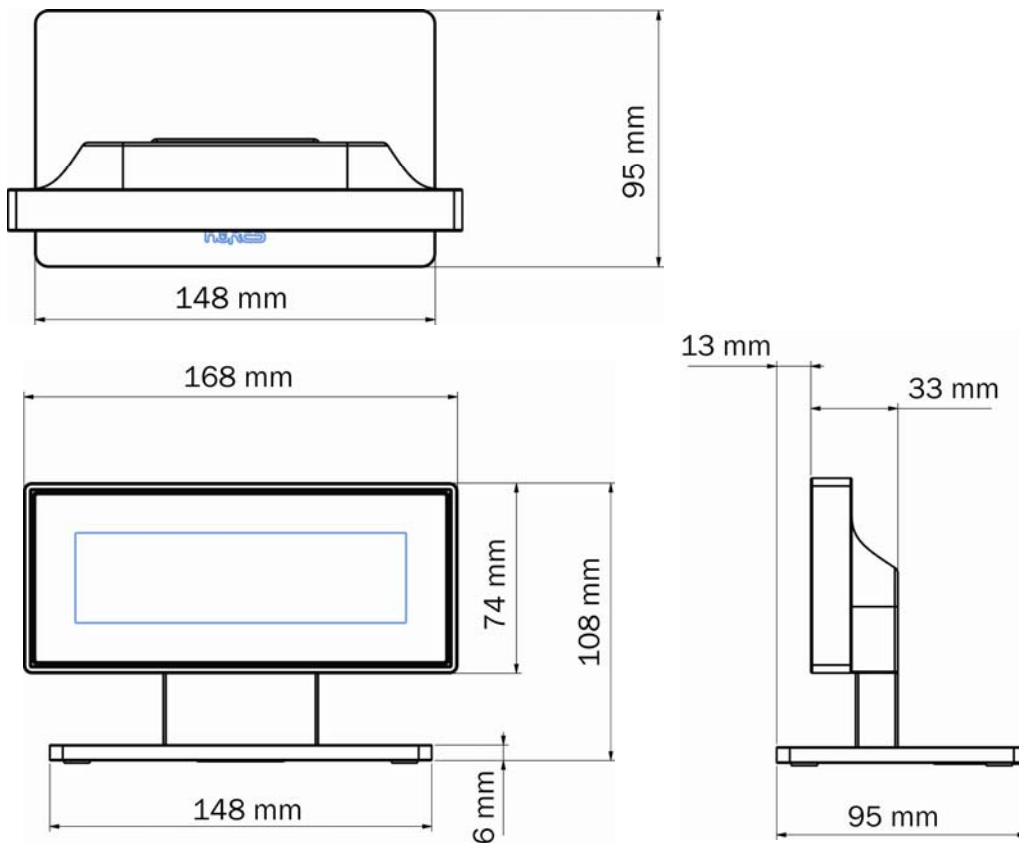

3 Features

1. Data can be displayed on 20 columns x 2 lines (USA/Euro/Arabic Symbol).
2. System command set and configuration stored in non-volatile Flash ROM.
3. Command emulation modes include: POS7300, EPSON ESC/POS, DSP800, ADM787/
ADM788, AEDEX/ EMAX, UTC, and CD5220.
4. USB Virtual COM interface (driver required)
5. Reverse characters can be specified using the POS7300/EPSON command set.
6. Versatile tilt angle 0 to 90 degrees.

4 Specification

Item	Description
Display method	White LED Backlight FSTN Negative Transmissive LCD
Number of characters	40 characters (20 x 2 Line)
Character font	12 x 32 Dot matrix
Display color	White-Black
Brightness	1000 cd/m ²
Character type	96 alphanumeric 28 international character sets
Character size	6.33mm x 16.93mm
Power supply	USB +5V Power Supply
Power consumption	0.3 W
MTBF	50,000 hours (power on time)
View area dimensions	130.2mm (W) x 37.6mm (H)
Viewing angle	30 ~ 60 degree (Vertical) -45 ~ 45 degree (Horizontal)
Display tilt angle	0~90 degree
Operating temperature	5°C ~ 45°C
Operating Humidity	30% ~ 85%
Storage Temperature	-10 °C ~ 55 °C
Storage Humidity	10% ~85% (non-condensing)

5 Interface

USB Virtual COM. Driver installation required.

5-1 Connector Pin Definition

- Connector type: Pitch 1.25mm 4 pin USB connector

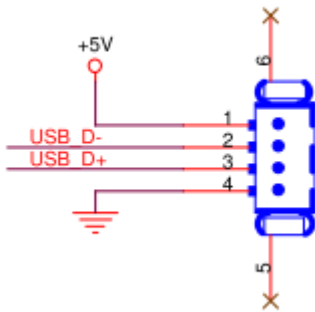

- USB Pin Definition

Pin #	Definition
1	+5V_VBUS
2	USB_D-
3	USB_D+
4	GND

6 Driver Installation

To download the most recent drivers and utilities, and obtain advice regarding the installation of your equipment, please visit the AURES Technical Support Website:

www.ares-support.fr (French)

www.ares-support.fr/UK (English)

www.ares-support.fr/GE (German)

7 Software Status Setting Commands

When the device is POWER ON, it will read the Flash ROM Setting to set the **Command Type, Baud Rate, Parity, Data Length, Demo Mode and International Character**. User can re-set the Software Status Setting Commands as following, and Status Setting will be saving to Flash ROM:

7-1 Baud Rate Setting Command

STX 05 B n ETX /Change the baud rate setting/
 ASCII Format STX 05 B n ETX
 Dec. Format [02] [05] [66] n [03]
 Hex. Format [02h][05h][42h] n [03h] n=30h, 31h, 36h, 37h
 Description Change the display communication baud rate.
 The baud rate setting can be selected from 4800 to 38400.

n	Baud rate
31h	4800
30h	9600
37h	19200
36h	38400

7-2 Parity Check Setting Command

STX 05 P n ETX /Change the Parity check setting/
 ASCII Format STX 05 P n ETX
 Dec. Format [02] [05] [80] n [03]
 Hex. Format [02h][05h][50h] n [03h] n=31h, 33h, 35h
 Description Change the display communication parity. Set 8 data bit and the parity set for even \ odd or non-parity.

n	Parity check
31h	None-parity
33h	Even-parity
35h	Odd-parity

7-3 Data Length Setting Command

STX 05 L n ETX /Change the Data Length Setting/
 ASCII Format STX 05 L n ETX
 Dec. Format [02] [05] [76] n [03]
 Hex. Format [02h][05h][4Ch] n [03h] n=37h, 38h
 Description Change the display communication data length. Set 8-bits or 7-bits data length.

n	Data Length
37h	7 bits
38h	8 bits

7-4 International Character Set Setting Command

STX 05 S n ETX /Change the international character set/
 ASCII Format STX 05 S n ETX
 Dec. Format [02] [05] [83] n [03]
 Hex. Format [02h][05h][53h] n [03h] $30h \leq n \leq 4Ch$
 Description Change the display international character font.

n	Character Set (20h - 7Fh)	Code Table (80H-FFH)	Note
30h	U.S.A.	CP-437 (USA, Standard Europe)	
31h	FRANCE	CP-858 (Multilingual + Euro Symbol)	
32h	GERMANY		
33h	U.K.		
34h	DENMARK I		
35h	SWEDEN		
36h	ITALY		
37h	SPAIN		
38h	JAPAN	Katakana	
39h	NORWAY	CP-858	
3Ah	DENMARK II	(Multilingual+ Euro Symbol)	
3Bh	Slawie		
3Ch	RUSSIA		
3Dh	U.S.A.	CP-860 (Portuguese)	
3Eh	U.K.	Greek	
3Fh	U.S.A.	CP-852 (Hungary)	
40h	U.S.A.	CP-862 (Hebrew)	
41h	U.S.A.	CP-863 (Canadian-French)	
42h	U.S.A.	CP-865 (Nordic)	
43h	U.S.A.	CP-866 (Cyrillic)	
44h	U.S.A.	Windows-1251 (Cyrillic)	
45h	U.S.A.	Windows-1252 (West European Latin)	
46h	U.S.A.	Windows-1255 (Hebrew)	
47h	U.S.A.	Windows-1257 (Baltic)	
48h	U.S.A.	Windows-1253 (Greek)	
49h	U.S.A.	Windows-1250 (East European Latin)	
4Ah	U.S.A.	Windows-1254 (Turkish)	
4Bh	Arabic		

7-5 Select International Character Set Command

STX 05 T n ETX	/Select International Character Set Command/
ASCII Format	STX 05 T n ETX
Dec. Format	[02] [05] [84] n [03]
Hex. Format	[02h][05h][54h] n [03h] 00h ≤ n ≤ 0Dh
Description	Select International Character Set

Select international character set (20H~7Fh) by command “STX 05 T n ETX”

n	International character set	n	International character set	n	International character set
00h	U.S.A.	06h	ITALY	0Ch	RUSSIA
01h	FRANCE	07h	SPAIN	0Dh	ARABIC
02h	GERMANY	08h	JAPAN		
03h	U.K.	09h	NORWAY		
04h	DENMARK I	0Ah	DENMARK II		
05h	SWEDEN	0Bh	SLAVONIC		

7-6 Select Character Code Table Command

STX 05 U n ETX	/Select Character Code Table Command/
ASCII Format	STX 05 U n ETX
Dec. Format	[02] [05] [85] n [03]
Hex. Format	[02h][05h][55h] n [03h] 00h ≤ n ≤ 15h
Description	Select Character Code Table

Select character code table (80H~FFh) by command “STX 05 U n ETX”

n	Character code table	n	Character code table	n	Character code table
00h	CP-437 (USA, Standard Europe)	08h	Greek	10h	Windows-1252 (West European Latin)
01h	Katakana (for Japan)	09h	CP-852 (Hungary)	11h	Windows-1253 (Greek)
02h	CP-850 (Multilingual)	0Ah	CP-862 (Hebrew)	12h	Windows-1250 (East European Latin)
03h	CP-860 (Portuguese)	0Bh	CP-866 (Cyrillic)	13h	CP-858 (Multilingual+ Euro Symbol)
04h	CP-863 (Canadian-French)	0Ch	Windows-1251 (Cyrillic)	14h	Arabic
05h	CP-865 (Nordic)	0Dh	Windows-1254 (Turkish)		
06h	Slawie	0Eh	Windows-1255 (Hebrew)		
07h	Russia	0Fh	Windows-1257 (Baltic)		

7-7 Command Type Setting Command

STX 05 C n ETX /Change the command type setting/
 ASCII Format STX 05 C n ETX
 Dec. Format [02] [05] [67] n [03]
 Hex. Format [02h][05h][43h] n [03h] $30h \leq n \leq 37h$
 Description This command will change the command type and initialize the display. The display emulation mode is based on DSP800/ ESC/ ADM 787/ POS7300/ AEDEX/ UTC/ CD5220 mode.

n	Command Type	n	Command Type
32h	POS7300	34h	AEDEX
31h	ESC/POS	35h	UTC/P
33h	ADM 787	36h	UTC/S
30h	DSP800	37h	CD5220

7-8 Run Demo message

STX 05 D 08 ETX /Run demo message/
 ASCII Format STX 05 D 08 ETX
 Dec. Format [02][05][68][08][03]
 Hex. Format [02h][05h][44h][08h][03h]
 Description Run demo message for the display.
 The display emulation mode is based on POS7300, DSP800, EPSON ESC/POS, CD5220 command type.

7-9 Show Firmware Version

STX 05 V 01 ETX /Show Firmware Version/
 ASCII Format STX 05 V 01 ETX
 Dec. Format [02][05][86][01][03]
 Hex. Format [02h][05h][56h][01h][03h]
 Description Show firmware version.

7-10 Graphic LCM Contrast Setting

STX F7 SOH n NUL /Set Graphic LCM Contrast Value/
 ASCII Format STX F7 SOH n NUL
 Dec. Format [02][247][01][n][00]
 Hex. Format [02h][F7h][01h][n][00h]
 Description Set Graphic LCM Contrast.
 Setting Value Range: 00h ~ 3Fh Default Value is 20h

7-11 Display Logo Command

STX FC 55 AA 55 AA /Display Logo Command/
 ASCII Format STX FC 55 AA 55 AA
 Dec. Format [02][252][85][170][85][170]
 Hex. Format [02h][FCh][55h][AAh][55h] [AAh]
 Description Displays the logo. Please ensure that the logo has been set with the Customer Display configuration utility before using this command.

8 Command List Table

Command Set	POS7300	CD5220	EPSON D101	UTC/S	UTC/P	AEDEX	ADM788	DSP800
Move cursor right	0	0	0					
Move cursor left	0	0	0					
Move cursor up	0	0	0					
Move cursor down	0	0	0					
Move cursor to right-most position	0	0	0					
Move cursor to left-most position	0	0	0					
Move cursor to home position	0	0	0					
Move cursor to bottom position	0	0	0					
Move cursor to specified position	0	0	0					0
Clear display screen	0	0	0	0			0	
Clear cursor line	0	0	0					
Blink display screen	0	0	0					0
Initialize display	0	0	0					0
Select character code table	0	0	0					
Select international character set	0	0	0					0
Select/cancel reverse character	0		0					
Overwrite mode	0	0	0	0				
Vertical scroll mode	0	0	0	0				
Horizontal scroll mode	0	0	0					
Set/cancel the window range	0	0	0					
Set starting/ending position of macro definition			0					
Execute and quit macro			0					
Execute self-test	0	0	0					0
Display time	0		0		0	0		
Display time continuously	0		0					
Display position	0			0				
Cursor on/off	0	0	0	0				
Change to UTC enhanced mode				0				
Change to UTC standard mode					0			
Write string to upper line	0	0			0	0		
Upper line message continuous scroll	0	0			0	0		
Bottom line message scroll continuously	0							
Message vertical down scroll continuously	0							
Message vertical upper scroll continuously	0							
Carriage return	0			0			0	
Line feed	0			0				
Back space	0			0				
Horizontal tab	0			0				
Command type select		0	0					0
Upper line message scroll once pass					0	0		
Change attention code					0	0		
Two line display					0	0		

Command Set	POS7300	CD5220	EPSON D101	UTC/S	UTC/P	AEDEX	ADM788	DSP800
Clear upper line and move cursor to upper left-end position							0	
Clear bottom line and move cursor to bottom left-end position							0	
Set period to upper line, last n position							0	
Set line blinking, upper line	0						0	
Clear line blinking, upper line	0						0	
Clear field 1 and move cursor to field 1, first position							0	
Clear field 2 and move cursor to field 2, first position							0	
Clear display range from n position to m position and move cursor to n position								0
Save the current displaying data to n layer for demo display								0
Specify period	0		0					
Specify comma	0		0					
Specify semicolon (period + comma)	0		0					

9 Command Details

9-1 POS7300 Series Command List

Command	Code (hex)	Function Description
ESC F A [DATA] CR	1B 46 41 [DATA] 0D	Write string to upper line ➤ Maximal [DATA] length is 40
ESC F B [DATA] CR	1B 46 42 [DATA] 0D	Write string to lower line ➤ Maximal [DATA] length is 40
ESC F D [DATA] CR	1B 46 44 [DATA] 0D	Upper line message scroll continuously ➤ Maximal [DATA] length is 40
ESC F O [DATA] CR	1B 46 4F [DATA] 0D	Bottom line message scroll continuously ➤ Maximal [DATA] length is 40
ESC P x y	1B 50 x y	Move cursor to specified position ➤ x = 1 ~ 14h, for columns location. ➤ y = 1 ~ 2, for lines location.
ESC _ n	1B 5F n	Set cursor on/off ➤ n = 00 ~ 01
ESC DC1	1B 11	Overwrite mode
ESC DC2	1B 12	Vertical scroll mode
ESC DC3	1B 13	Horizontal scroll mode
ESC @	1B 40	Initialize display
US MD1 n	1F 01 n	Message vertical upper scroll continuously ➤ n = 01 ~ 0Ch
US MD2 n	1F 02 n	Message vertical down scroll continuously ➤ n = 01 ~ 0Ch
US DC1 n	1F 11 n	Set line blinking ➤ n = '1' ~ '2' ■ n = '1' up line ■ n = '2' low line
US DC2 n	1F 12 n	Clear line blinking ➤ n = '1' ~ '2' ■ n = '1' up line ■ n = '2' low line
US , n	1F 2C n	Specify comma ➤ n = a displayable character code
US . n	1F 2E n	Specify period ➤ n = a displayable character code
US ; n	1F 3B n	Specify semicolon (period + comma) ➤ n = a displayable character code
US @	1F 40	Execute self - test
US E n	1F 45 n	Blink display screen ➤ n = 00h ~ FFh ■ n = 0 for no blink
US T h m	1F 54 h m	Display time ➤ $0 \leq h \leq 17h$, for hours setting. ➤ $0 \leq m \leq 3Bh$, for minutes setting.
US U	1F 55	Display time continuously
US r n	1F 72 n	Select/cancel reverse character. ➤ n = 00,01
NULL H	0 48	Move cursor up
NULL K	0 4B	Move cursor left
NULL M	0 4D	Move cursor right

Command	Code (hex)	Function Description
NULL P	0 50	Move cursor down
NULL G	0 47	Move cursor to left-most position
NULL O	0 4F	Move cursor to right-most position
BS	08	Back space
HT	09	Horizontal tab
LF	0A	Line feed
HOM	0B	Move cursor to home position
US B	1F 42	Move cursor to bottom position
CLR	0C	Clear display screen
CLR	12	
CR	0D	Carriage return
CAN	18	Clear cursor line, and clear string mode
DLE n	10 n	Display position ➤ n = 0 ~ 27h, for location.
ESC W n s x1 y1 x2 y2	1B 57 n s x1 y1 x2 y2	Set or cancel the window range ➤ n = 1 ~ 4, for window number ➤ s = 0: cancel s = 1: set ➤ $1 \leq x1 \leq x2 \leq 14h$, for columns location. ➤ $1 \leq y1 \leq y2 \leq 2$, for lines location.
ESC R n	1B 52 n	Select international character set (20H~7Fh). ➤ n = 00 ~ 0Dh. See note *1
ESC t n	1B 74 n	Select character code table (80H~FFh). ➤ n = 00 ~ 15h. See note *2

Note:

1. Select international character set (20H~7Fh) by command “ESC R n”

n	International character set	n	International character set	n	International character set
00h	U.S.A.	05h	SWEDEN	0Ah	DENMARK II
01h	FRANCE	06h	ITALY	0Bh	SLAVONIC
02h	GERMANY	07h	SPAIN	0Ch	RUSSIA
03h	U.K.	08h	JAPAN	0Dh	ARABIC
04h	DENMARK I	09h	NORWAY		

2. Select character code table (80H~FFh) by command “ESC t n”

n	Character code table	n	Character code table	n	Character code table
00h	CP-437 (USA, Standard Europe)	08h	Greek	10h	Windows-1252 (West European Latin)
01h	Katakana (for Japan)	09h	CP-852 (Hungary)	11h	Windows-1253 (Greek)
02h	CP-850 (Multilingual)	0Ah	CP-862 (Hebrew)	12h	Windows-1250 (East European Latin)
03h	CP-860 (Portuguese)	0Bh	CP-866 (Cyrillic)	13h	CP-858 (Multilingual+ Euro Symbol)
04h	CP-863 (Canadian-French)	0Ch	Windows-1251 (Cyrillic)	14h	Arabic
05h	CP-865 (Nordic)	0Dh	Windows-1254 (Turkish)		
06h	Slawie	0Eh	Windows-1255 (Hebrew)		
07h	Russia	0Fh	Windows-1257 (Baltic)		

9-2 CD5220 Standard Mode Command List

Command	Code (hex)	Function Description
ESC DC1	1B 11	Overwrite mode
US SOH	1F 01	
ESC DC2	1B 12	Vertical scroll mode
US STX	1F 02	
ESC DC3	1B 13	Horizontal scroll mode
US ETX	1F 03	
ESC Q A [DATA] CR	1B 51 41 [DATA] 0D	Set the string display mode, write string to upper line. *1 ➤ Maximal [DATA] length is 20
ESC Q B [DATA] CR	1B 51 42 [DATA] 0D	Set the string display mode, write string to lower line. *1 ➤ Maximal [DATA] length is 20
ESC Q D [DATA] CR	1B 51 44 [DATA] 0D	Upper line message scroll continuously. *1 *2 ➤ Maximal [DATA] length is 40
ESD [D	1B 5B 44	Move cursor left
BS	08	
ESC [C	1B 5B 43	Move cursor right
HT	09	
ESC [A	1B 5B 41	Move cursor up
US LF	1F 0A	
ESC [B	1B 5B 42	Move cursor down
LF	0A	
ESC [H	1B 5B 48	Move cursor to home position
HOM	0B	
ESC [L	1B 5B 4C	Move cursor to left-most position
CR	0D	
ESC [R	1B 5B 52	Move cursor to right-most position
US CR	1F 0D	
ESC [K	1B 5B 4B	Move cursor to bottom position
US B	1F 42	
ESC # n	1B 23 n	Command type select ➤ n = 30h ~ 37h
US @	1F 40	Execute self test
US E n	1F 45 n	Blink display screen ➤ n = 00h ~ FFh ■ n = 0 for no blink
ESC I x y	1B 6C x y	Move cursor to specified position ➤ x = 1 ~ 14h, for columns location. ➤ y = 1,2, for lines location.
US \$ x y	1F 24 x y	
ESC @	1B 40	Initialize display
ESC W s x1 x2 y	1B 57 s x1 x2 y	Set or cancel the window range at horizontal scroll mode ➤ $1 \leq x1 \leq x2 \leq 14h$, for columns location. ➤ y = 1~2, for lines location. ➤ s = 0: cancel s = 1: set
CLR	0C	Clear display screen, and clear string mode
CAN	18	Clear cursor line, and clear string mode

Command	Code (hex)	Function Description
ESC _ n	1B 5F n	Set cursor on/off ➤ n = 1: cursor on n = 0: cursor off
ESC f n	1B 66 n	Select international Character ➤ About n, refer. *3
ESC c n	1B 63 n	Select character code table ➤ About n, refer. *4

Note:

1. While using command “ESC Q A” or “ESC Q B”, other commands cannot be used except when using command “CLR” or “CAN” to change operating mode.
2. When using command “ESC Q D”, the upper line message will scroll continuously until a new command is received, it will then clear the upper line and move the cursor to the upper left-end position.
3. Select the international Character set (20h – 7Fh) by command “ESC f n”.

Parameter “n”		International Character Set	Parameter “n”		International Character Set
Character	Hex		Character	Hex	
‘A’	41h	U.S.A.	‘W’	57h	Sweden
‘G’	47h	Germany	‘D’	44h	Denmark I
‘I’	49h	Italy	‘E’	45h	Denmark II
‘J’	4Ah	Japan	‘L’	4Ch	Slavonic
‘U’	55h	U.K.	‘R’	52h	Russia
‘F’	46h	France	‘B’	42h	Arabic
‘S’	53h	Spain			
‘N’	4Eh	Norway			

4. Select character code table (80H-FFH) by command “ESC c n”.

Parameter “n”		character Code Table
Character	Hex	
‘A’	41h	Compliance with ASCII code (CP-437)
‘J’	4Ah	Compliance with JIS code (Katakana)
‘L’	4Ch	Compliance with Slawie code
‘R’	52h	Compliance with RUSSIA code
‘M’	4Dh	CP-850 (Multilingual)
‘P’	50h	CP-858 (Multilingual+ Euro Symbol)
‘p’	70h	CP-860 (Portuguese)
‘F’	46h	CP-863 (Canadian-French)
‘N’	4Eh	CP-865 (Nordic)
‘u’	75h	CP-852 (Hungary)
‘H’	48h	CP-862 (Hebrew)
‘C’	43h	CP-866 (Cyrillic)
‘G’	47h	Greek
‘c’	63h	Windows-1251 (Cyrillic)
‘W’	57h	Windows-1252 (West European Latin)
‘h’	68h	Windows-1255 (Hebrew)
‘B’	42h	Windows-1257 (Baltic)
‘g’	67h	Windows-1253 (Greek)
‘E’	45h	Windows-1250 (East European Latin)
‘T’	54h	Windows-1254 (Turkish)
‘I’	49h	Arabic

9-3 UTC Standard Mode Command List

Command	Code (hex)	Function Description
BS	08	Back space
HT	09	Horizontal tab
LF	0A	Line feed
CR	0D	Carriage return
DLE n	10 n	Display position ➤ n = 0 ~ 27h, for location.
DC1	11	Over write display mode
DC2	12	Vertical scroll mode
DC3	13	Cursor on
DC4	14	Cursor off
US	1F	Clear display
ESC d	1B 64	Change to UTC enhanced mode

9-4 UTC Enhanced Mode Command List

Command	Code (hex)	Function Description
ESC u A [DATA] CR	1B 75 41 [DATA] 0D	Upper line display ➤ Maximal [DATA] length is 20
ESC u B [DATA] CR	1B 75 42 [DATA] 0D	Bottom line display ➤ Maximal [DATA] length is 20
ESC u D [DATA] CR	1B 75 44 [DATA] 0D	Upper line message scroll continuously ➤ Maximal [DATA] length is 40
ESC u E h h : m m CR	1B 75 45 h h ':' m m 0D	Display time ➤ h, m = '0' ~ '9'
ESC u F [DATA] CR	1B 75 46 [DATA] 0D	Upper line message scroll Once pass ➤ Maximal [DATA] length is 40
ESC u H n m CR	1B 75 48 n m 0D	Change attention code ➤ n = 1 ~ 20h ➤ m = 1 ~ 20h
ESC u I [DATA] CR	1B 75 49 [DATA] 0D	Two line display ➤ Maximal [DATA] length is 40
ESC RS CR	1B 0F 0D	Change to UTC standard mode

9-5 AEDEX/EMAX Mode Command List

Command	Code (hex)	Function Description
! # 1 [DATA] CR	21 23 31 [DATA] 0D	Upper line display ➤ Maximal [DATA] length is 20
! # 2 [DATA] CR	21 23 32 [DATA] 0D	Bottom line display ➤ Maximal [DATA] length is 20
! # 4 [DATA] CR	21 23 34 [DATA] 0D	Upper line message scroll ➤ Maximal [DATA] length is 60
! # 5 h h : m m CR	21 23 35 h h ':' m m 0D	Display time ➤ h, m = '0' ~ '9'
! # 8 n m CR	21 23 38 n m 0D	Change attention code ➤ n, m = 1 ~ 20
! # 9 [DATA] CR	21 23 39 [DATA] 0D	Two line display ➤ Maximal [DATA] length is 40
! # 6 [DATA] CR	21 23 36 [DATA] 0D	Upper line message scroll once pass ➤ Maximal [DATA] length is 60

9-6 ADM787/788 mode command list

Command	Code (hex)	Function Description
CLR	0C	Clear display
CR	0D	Carriage return
SLE1	0E	Clear upper line and move cursor to upper left-end position
SLE2	0F	Clear bottom line and move, Cursor to bottom left-end position
DC0 n	10 n	Set period to upper line last n position ➤ n = 31H ~ 37H
DC1 n	11 n	Set line blinking, upper line ➤ n = '1' ~ '2' ■ n = '1': up line ■ n = '2': low line
DC2 n	12 n	Clear line blinking, upper line ➤ n = '1' ~ '2' ■ n = '1': up line ■ n = '2': low line
SF1	1E	Clear field 1 and move cursor to field 1, first position
SF2	1F	Clear field 2 and move cursor to field 2, first position

9-7 DSP800 Mode Command List

Command	Code (hex)	Function Description
EOT SOH I n ETB	04 01 49 n 17	Select international character set ➤ n = 00 ~ 1Fh or 30 ~ 4Fh See note *1
EOT SOH P n ETB	04 01 50 n 17	Move cursor to specified position ➤ n = 31h ~ 58h
EOT SOH C n m ETB	04 01 43 n m 17	Clear display range from n position to m position and move cursor to n position ➤ 31h ≤ n ≤ m ≤ 58h
EOT SOH S n ETB	04 01 53 n 17	Save current view message to n layer for demo view data ➤ n = 31h ~ 35h
EOT SOH D n m ETB	04 01 44 n m 17	Display the saved demo message ➤ n = 31h ~ 4Fh ➤ m = 31h ~ 33h
EOT SOH F n ETB	04 01 46 n 17 00h ≤ n ≤ FFh	Blink display Screen ➤ n = 00h ~ FFh, n = 0 for no blink
EOT SOH # n ETB	04 01 23 n 17 n = 30~37h	Command type select
EOT SOH % ETB	04 01 25 17	Initialize display
EOT SOH @ ETB	04 01 40 17	Execute self-test

Note:

1. Select international character set (20H~7Fh) by command “EOT SOH I n ETB”

n	International character set	n	International character set	n	International character set
00h	U.S.A.	05h	SWEDEN	0Ah	DENMARK II
01h	FRANCE	06h	ITALY	0Bh	SLAVONIC
02h	GERMANY	07h	SPAIN	0Ch	RUSSIA
03h	U.K.	08h	JAPAN	0Dh	ARABIC
04h	DENMARK I	09h	NORWAY		
30h	U.S.A.	35h	SWEDEN	3Ah	DENMARK II
31h	FRANCE	36h	ITALY	3Bh	SLAVONIC
32h	GERMANY	37h	SPAIN	3Ch	RUSSIA
33h	U.K.	38h	JAPAN	3Dh	ARABIC
34h	DENMARK I	39h	NORWAY		

9-8 EPSON ESC/POS Command List

Command	Code (hex)	Function Description
US r n	1F 72 n	Select/cancel reverse character. ➤ n = 00,01
US MD1	1F 01	Specify overwrite mode.
US MD2	1F 02	Specify vertical scroll mode.
US MD3	1F 03	Specify horizontal scroll mode.
CAN	18	Clear cursor line
ESC # n	1B 23 n	Command type select ➤ n = 30h ~ 37h
US C n	1F 43 n	Set cursor on/off ➤ n = 00, 01
BS	08	Move cursor left
HT	09	Move cursor right
US LF	1F 0A	Move cursor up
LF	0A	Move cursor down
US CR	1F 0D	Move cursor to right-most position
CR	0D	Move cursor to left-most position
HOM	0B	Move cursor to home position
US B	1F 42	Move cursor to bottom position
US \$ x y	1F 24 x y	Move cursor to specified position ➤ x = 1 ~ 14h, for columns location. ➤ y = 1 ~ 2, for lines location.
CLR	0C	Clear display screen
US E n	1F 45 n	Blink display screen ➤ n = 00h ~ FFh n = 0 for no blink
ESC @	1B 40	Initialize display
US , n	1F 2C n	Specify comma ➤ n = a displayable character code
US . n	1F 2E n	Specify period ➤ n = a displayable character code
US ; n	1F 3B n	Specify semicolon (period + comma) ➤ n = a displayable character code
US :	1F 3A	Set starting/ending position of macro definition. Ex.: 1F 3A ... (macro string) ... 1F 3A
US ^ n m	1F 5E n m	Execute and quit macro. It's an interval of n between the two words. It's an interval of m between the two strings. ➤ $00 \leq (n, m) \leq FFh$ ■ n = Word time ■ m = show string time
US @	1F 40	Execute self - test
US T h m	1F 54 h m	Display time ➤ $0 \leq h \leq 17h$, for hours setting. ➤ $0 \leq m \leq 3Bh$, for minutes setting.
US U	1F 55	Display time continuously

Command	Code (hex)	Function Description
ESC W n s x1 y1 x2 y2	1B 57 n s x1 y1 x2 y2	Set or cancel the window range ➤ n = 1 ~ 4, for window number ➤ s = 0: cancel s = 1: set ➤ 1 ≤ x1 ≤ x2 ≤ 14h, for columns location. ➤ 1 ≤ y1 ≤ y2 ≤ 2, for lines location.
ESC R n	1B 52 n	Select international character set (20H~7Fh). ➤ n = 00 ~ 0Dh. See note *1
ESC t n	1B 74 n	Select character code table (80H~FFh). ➤ n = 00 ~ 15h. See note *2

Note:

1. Select international character set (20H~7Fh) by command “ESC R n”

n	International character set	n	International character set	n	International character set
00h	U.S.A.	05h	SWEDEN	0Ah	DENMARK II
01h	FRANCE	06h	ITALY	0Bh	SLAVONIC
02h	GERMANY	07h	SPAIN	0Ch	RUSSIA
03h	U.K.	08h	JAPAN	0Dh	ARABIC
04h	DENMARK I	09h	NORWAY		

2. Select character code table (80H~FFh) by command “ESC t n”

n	Character code table	n	Character code table	n	Character code table
00h	CP-437 (USA, Standard Europe)	08h	Greek	10h	Windows-1252 (West European Latin)
01h	Katakana (for Japan)	09h	CP-852 (Hungary)	11h	Windows-1253 (Greek)
02h	CP-850 (Multilingual)	0Ah	CP-862 (Hebrew)	12h	Windows-1250 (East European Latin)
03h	CP-860 (Portuguese)	0Bh	CP-866 (Cyrillic)	13h	CP-858 (Multilingual+ Euro Symbol)
04h	CP-863 (Canadian-French)	0Ch	Windows-1251 (Cyrillic)	14h	Arabic
05h	CP-865 (Nordic)	0Dh	Windows-1254 (Turkish)		
06h	Slawie	0Eh	Windows-1255 (Hebrew)		
07h	Russia	0Fh	Windows-1257 (Baltic)		

10 Character Set

10-1 Character Code 20H – 7FH

International Character Sets

Character Code Number													
Country	Hex	23	24	40	5B	5C	5D	5E	60	7B	7C	7D	7E
	Dec	35	36	64	91	92	93	94	96	123	124	125	126
U.S.A	#	\$	@	[\]	^	`	{		}	~	
France	#	\$	à	°	ç	§	^	`	é	ù	è	¨	
Germany	#	\$	§	Ä	Ö	Ü	^	`	ä	ö	ü	ß	
U.K	£	\$	@	[\]	^	`	{		}	~	
Denmark I	#	\$	@	Æ	Ø	Å	^	`	æ	ø	å	~	
Sweden	#	α	É	Ä	Ö	Å	Ü	é	ä	ö	å	ü	
Italy	#	\$	@	°	\	é	^	ù	à	ò	è	ì	
Spain	Pts	\$	@	i	Ñ	¿	^	`	¨	ñ	}	~	
Japan	#	\$	@	[¥]	^	`	{		}	~	
Norway	#	α	É	Æ	Ø	Å	Ü	é	æ	ø	å	ü	
Denmark II	#	\$	É	Æ	Ø	Å	Ü	é	æ	ø	å	ü	
Slavonic	#	\$	@	[\]	^	`	{		}	~	
Russia	#	\$	@	[\]	^	`	{		}	~	

USA, Standard Character Sets

	00h	01h	02h	03h	04h	05h	06h	07h	08h	09h	0Ah	0Bh	0Ch	0Dh	0Eh	0Fh
20h		!	“	#	\$	%	&	'	()	*	+	,	-	.	/
30h	0	1	2	3	4	5	6	7	8	9	:	;	<	=	>	?
40h	@	A	B	C	D	E	F	G	H	I	J	K	L	M	N	O
50h	P	Q	R	S	T	U	V	W	X	Y	Z	[\]	^	_
60h	`	a	b	c	d	e	f	g	h	i	j	k	l	m	n	o
70h	p	q	r	s	t	u	v	w	x	y	z	{		}	~	

10-2 Character Code 80H – FFH

CP-437 (USA, Standard Europe)

	00h	01h	02h	03h	04h	05h	06h	07h	08h	09h	0Ah	0Bh	0Ch	0Dh	0Eh	0Fh
80h	Ç	ü	é	â	ä	à	å	ç	ê	ë	è	ï	î	ì	Ä	Å
90h	É	æ	Æ	ô	ö	ò	û	ù	ÿ	Ö	Ü	ø	£	¥	Pts	f
A0h	á	í	ó	ú	ñ	Ñ	<u>a</u>	<u>o</u>	¿	¬	¬	½	¼	¡	«	»
B0h	⋯	⋮	⋭		┌	≡	≡	≡	≡	≡	≡	≡	≡	≡	≡	≡
C0h	L	┌	┐	└	—	├	┤	┥	┦	┧	┨	┩	┪	┫	┬	┴
D0h	⌌	⌍	⌎	⌏	⌐	⌑	⌒	⌓	⌔	⌕	⌖	■	■	■	■	■
E0h	α	β	Γ	π	Σ	σ	μ	τ	Φ	Θ	Ω	δ	∞	φ	ε	∩
F0h	≡	±	≥	≤		J	÷	≈	°	·	·	√	"	²	■	

CP-850 (Multilingual)

	00h	01h	02h	03h	04h	05h	06h	07h	08h	09h	0Ah	0Bh	0Ch	0Dh	0Eh	0Fh
80h	Ç	ü	é	â	ä	à	å	ç	ê	ë	è	ï	î	ì	Ä	Å
90h	É	æ	Æ	ô	ö	ò	û	ù	ÿ	Ö	Ü	ø	£	Ø	×	f
A0h	á	í	ó	ú	ñ	Ñ	<u>a</u>	<u>o</u>	¿	®	¬	½	¼	¡	«	»
B0h	⋯	⋮	⋭		┌	Á	Â	À	©	≡	≡	≡	≡	ø	¥	┐
C0h	L	┌	┐	└	—	├	ã	Ã	ℒ	℞	ℓ	≡	≡	≡	≡	α
D0h	ø	Ð	Ê	Ë	È	ı	í	î	ï	┘	┙	■	■	ı	ı	■
E0h	Ó	β	Ô	Ò	õ	Õ	μ	þ	Ɔ	Ú	Û	Ü	ý	Ý	—	'
F0h	-	±	≡	¾	¶	§	÷	,	°	¨	·	¹	³	²	■	

CP-858 (Multilingual + Euro Symbol)

	00h	01h	02h	03h	04h	05h	06h	07h	08h	09h	0Ah	0Bh	0Ch	0Dh	0Eh	0Fh
80h	Ç	ü	é	â	ä	à	å	ç	ê	ë	è	ï	î	ì	Ä	Å
90h	É	æ	Æ	ô	ö	ò	û	ù	ÿ	Ö	Ü	ø	£	Ø	×	f
A0h	á	í	ó	ú	ñ	Ñ	<u>a</u>	<u>o</u>	¿	®	¬	½	¼	¡	«	»
B0h	⋯	⋮	⋭		┌	Á	Â	À	©	≡	≡	≡	≡	ø	¥	┐
C0h	L	┌	┐	└	—	├	ã	Ã	ℒ	℞	ℓ	≡	≡	≡	≡	α
D0h	ø	Ð	Ê	Ë	È	€	ı	î	ï	┘	┙	■	■	ı	ı	■
E0h	Ó	β	Ô	Ò	õ	Õ	μ	þ	Ɔ	Ú	Û	Ü	ý	Ý	—	'
F0h	-	±	≡	¾	¶	§	÷	,	°	¨	·	¹	³	²	■	

Katakana for Japan

	00h	01h	02h	03h	04h	05h	06h	07h	08h	09h	0Ah	0Bh	0Ch	0Dh	0Eh	0Fh
80h	α	β	γ	△	ε	η	θ	λ	μ	π	ρ	σ	τ	Φ	Ω	Σ
90h	£	§	IE	IR	∫	\bar{x}	\bar{A}	⁻¹	²	³	^x	^{1/2}	^{1/}	√	±	■
A0h		。	「	」	、	・	ヲ	ア	イ	ウ	エ	オ	ヤ	ユ	ヨ	ツ
B0h	ー	ア	イ	ウ	エ	オ	カ	キ	ク	ケ	コ	サ	シ	ス	セ	ソ
C0h	タ	チ	ツ	テ	ト	ナ	ニ	ヌ	ネ	ノ	ハ	ヒ	フ	ヘ	ホ	マ
D0h	ミ	ム	メ	モ	ヤ	ユ	ヨ	ラ	リ	ル	レ	ロ	ワ	ン	ゝ	゜
E0h	↑	↓	←	→	↶	↷	↸	↹	↺	↻	”	“	«	»	∴	∵
F0h	≤	≥	≠	≡	∥		⊥	∞	□	~	~	≡	〒	♀	⊕	□

Slawie

	00h	01h	02h	03h	04h	05h	06h	07h	08h	09h	0Ah	0Bh	0Ch	0Dh	0Eh	0Fh
80h	Ç	ü	é	â	ä	û	ć	ç	ł	ë	õ	õ	î	ź	ä	ć
90h	é	ł	í	ô	ö	ł	ĩ	ś	ś	Ö	Ü	ł	ł	ł	×	č
A0h	á	í	ó	ú	ą	ą	ż	ż	ę	ę		ż	č	ş	«	»
B0h	•••	••••	•••••		┌	á	â	ě	ş					ł	ł	
C0h					—	+	ă	ă						=		α
D0h	đ	đ	đ	ë	đ	ň	í	î	ě			■	■	ł	û	■
E0h	ó	β	ô	ń	ń	ň	š	š	ř	ú	ř	ũ	ý	ý	ł	´
F0h	—	”	•	ˇ	ˇ	§	÷	˘	°	¨	˙	ú	ř	ř	■	

Russia

	00h	01h	02h	03h	04h	05h	06h	07h	08h	09h	0Ah	0Bh	0Ch	0Dh	0Eh	0Fh
80h	А	Б	В	Г	Д	Е	Ж	З	И	Й	К	Л	М	Н	О	П
90h	Р	С	Т	У	Ф	Х	Ц	Ч	Ш	Щ	Ъ	Ы	Ь	Э	Ю	Я
A0h	а	б	в	г	д	е	ж	з	и	й	к	л	м	н	о	п
B0h																
C0h																
D0h																
E0h	р	с	т	у	ф	х	ц	ч	ш	щ	ъ	ы	ь	э	ю	я
F0h	ə	ƒ	Ɔ	Ң	θ	Ƴ	Ƴ	h	ə	ƒ	Ɔ	Ң	θ	Ƴ	Ƴ	

CP-860 (Portuguese)

	00h	01h	02h	03h	04h	05h	06h	07h	08h	09h	0Ah	0Bh	0Ch	0Dh	0Eh	0Fh
80h	Ç	ü	é	â	ã	à	Á	ç	ê	Ê	è	í	Ô	ì	Ã	Â
90h	É	À	È	ô	õ	ò	Ú	ù	ì	Õ	Ü	ç	£	Ù	Þ	Ó
A0h	á	í	ó	ú	ñ	Ñ	ä	ö	ı	Ò	¬	½	¼	ı	«	»
B0h	⋮	⋮	⋮		┌	┐	└	┘	┌	┐	└	┘	└	┘	└	┘
C0h	L	└	┐	┌	┐	└	┘	┌	┐	└	┘	└	┘	└	┘	└
D0h	└	┐	┐	└	┘	└	┘	└	┘	└	┘	■	■	■	■	■
E0h	α	β	Γ	π	Σ	σ	μ	τ	Φ	Θ	Ω	δ	∞	φ	ε	∩
F0h	≡	±	≥	≤		J	÷	≈	°	·	·	√	"	²	■	

Greek

	00h	01h	02h	03h	04h	05h	06h	07h	08h	09h	0Ah	0Bh	0Ch	0Dh	0Eh	0Fh
80h	A	B	Γ	Δ	E	Z	H	Θ	I	K	Λ	M	N	Ξ	O	Π
90h	P	Σ	T	Υ	Φ	X	Ψ	Ω	α	β	γ	δ	ε	ζ	η	θ
A0h	ι	κ	λ	μ	ν	ξ	ο	π	ρ	σ	ς	τ	υ	φ	χ	ψ
B0h																
C0h																
D0h																
E0h	ω															
F0h										£				-		

CP-852 (Hungary)

	00h	01h	02h	03h	04h	05h	06h	07h	08h	09h	0Ah	0Bh	0Ch	0Dh	0Eh	0Fh
80h	Ç	ü	é	â	ä	ű	ć	ç	ł	ë	Ő	ő	î	Ž	Ä	Ć
90h	É	Í	í	ô	ö	Ĺ	ĺ	Ś	ś	Ö	Ü	ř	ř	Ł	×	č
A0h	á	í	Ó	ú	Ą	ą	Ž	ž	Ę	ę	¬	ż	Č	ş	«	»
B0h	⋮	⋮	⋮		┌	┐	Á	Â	Ě	Š	ř	└	┘	Ž	ž	└
C0h	L	└	┐	┌	┐	└	┘	Ă	ă	Ĺ	└	┘	└	┘	└	┘
D0h	đ	Đ	Đ	Ě	đ	Ń	ń	Î	ě	└	┘	■	■	└	┘	■
E0h	Ó	β	Ô	Ń	ń	ň	Š	š	Ř	Ú	ř	Ű	ý	Ý	ı	'
F0h	-	"	˘	ˇ	˘	§	÷	˘	°	˘	˘	ű	Ř	ř	■	

CP-862 (Hebrew)

	00h	01h	02h	03h	04h	05h	06h	07h	08h	09h	0Ah	0Bh	0Ch	0Dh	0Eh	0Fh
80h	א	ב	ג	ד	ה	ו	ז	ח	ט	י	ך	כ	ל	מ	נ	ן
90h	ס	ע	פ	צ	ק	ר	ש	ת	ף	ץ	£	¥	₪	₪	₪	₪
A0h	á	í	ó	ú	ñ	Ñ	ä	ö	¿	¬	½	¼	¡	«	»	
B0h	▒	▒	▒		├	┤	┥	┦	┧	┨	┩	┪	┫	┬	┭	┮
C0h	┯	┰	┱	┲	┳	┴	┵	┶	┷	┸	┹	┺	┻	┼	┽	┾
D0h	┿	␣	␣	␣	␣	␣	␣	␣	␣	␣	█	█	█	█	█	█
E0h	α	β	Γ	π	Σ	σ	μ	τ	Φ	Θ	Ω	δ	∞	φ	ε	∩
F0h	≡	±	≥	≤		J	÷	≈	°	·	·	√	n	²	■	

CP-863 (Canadian- French)

	00h	01h	02h	03h	04h	05h	06h	07h	08h	09h	0Ah	0Bh	0Ch	0Dh	0Eh	0Fh
80h	Ç	ü	é	â	Â	à	¶	ç	ê	ë	è	ï	î	Û	Ä	§
90h	É	È	Ê	ô	Ë	ï	û	ù	æ	Û	Ü	ø	£	Ü	Û	f
A0h	ı	ı	ó	ú	ı	ı	ı	ı	ı	ı	ı	½	¼	¾	«	»
B0h	▒	▒	▒		├	┤	┥	┦	┧	┨	┩	┪	┫	┬	┭	┮
C0h	┯	┰	┱	┲	┳	┴	┵	┶	┷	┸	┹	┺	┻	┼	┽	┾
D0h	┿	␣	␣	␣	␣	␣	␣	␣	␣	␣	␣	█	█	█	█	█
E0h	α	β	Γ	π	Σ	σ	μ	τ	Φ	Θ	Ω	δ	∞	φ	ε	∩
F0h	≡	±	≥	≤		J	÷	≈	°	·	·	√	n	²	■	

CP-865 (Nordic)

	00h	01h	02h	03h	04h	05h	06h	07h	08h	09h	0Ah	0Bh	0Ch	0Dh	0Eh	0Fh
80h	Ç	ü	é	â	ä	à	å	ç	ê	ë	è	ï	î	ì	Ä	Å
90h	É	æ	Æ	ô	ö	ò	û	ù	ÿ	Ö	Ü	ø	£	Ø	Pt	f
A0h	á	í	ó	ú	ñ	Ñ	ä	ö	¿	¬	½	¼	¡	«	»	α
B0h	▒	▒	▒		├	┤	┥	┦	┧	┨	┩	┪	┫	┬	┭	┮
C0h	┯	┰	┱	┲	┳	┴	┵	┶	┷	┸	┹	┺	┻	┼	┽	┾
D0h	┿	␣	␣	␣	␣	␣	␣	␣	␣	␣	␣	█	█	█	█	█
E0h	α	β	Γ	π	Σ	σ	μ	τ	Φ	Θ	Ω	δ	∞	φ	ε	∩
F0h	≡	±	≥	≤		J	÷	≈	°	·	·	√	n	²	■	

CP-866 (Cyrillic)

	00h	01h	02h	03h	04h	05h	06h	07h	08h	09h	0Ah	0Bh	0Ch	0Dh	0Eh	0Fh
80h	А	Б	В	Г	Д	Е	Ж	З	И	Й	К	Л	М	Н	О	П
90h	Р	С	Т	У	Ф	Х	Ц	Ч	Ш	Щ	Ъ	Ы	Ь	Э	Ю	Я
A0h	а	б	в	г	д	е	ж	з	и	й	к	л	м	н	о	п
B0h	␣	␣	␣	␣	␣	␣	␣	␣	␣	␣	␣	␣	␣	␣	␣	␣
C0h	␣	␣	␣	␣	␣	␣	␣	␣	␣	␣	␣	␣	␣	␣	␣	␣
D0h	␣	␣	␣	␣	␣	␣	␣	␣	␣	␣	␣	␣	␣	␣	␣	␣
E0h	р	с	т	у	ф	х	ц	ч	ш	щ	ъ	ы	ь	э	ю	я
F0h	Ë	ë	Є	є	İ	ï	Ÿ	ÿ	°	·	·	√	№	α	■	

Windows-1250 (Central Europe)

	00h	01h	02h	03h	04h	05h	06h	07h	08h	09h	0Ah	0Bh	0Ch	0Dh	0Eh	0Fh
80h	€		,		„	…	†	‡		‰	Š	‹	Ś	Ť	Ž	Ž
90h		‘	’	“	”	•	–	—		™	š	›	ś	ť	ž	ž
A0h		ˇ	ˇ	ł	α	Ą	ı	§	¨	©	Ş	«	¬		®	Ž
B0h	°	±	¸	ł	´	μ	¶	·	¸	ą	ş	»	ł	”	ı	ž
C0h	Ř	Á	Â	Ǻ	Ä	Í	Ć	Ç	Č	É	Ę	Ë	Ě	Í	Î	Ď
D0h	Đ	Ń	Ň	Ó	Ô	Õ	Ö	×	Ř	Ú	Ú	Ů	Ü	Ý	Ť	ß
E0h	ř	á	â	ǻ	ä	í	ć	ç	č	é	ę	ë	ě	í	î	ď
F0h	đ	ń	ň	ó	ô	õ	ö	÷	ř	ú	ú	ů	ü	ý	ť	·

Windows-1251 (Cyrillic)

	00h	01h	02h	03h	04h	05h	06h	07h	08h	09h	0Ah	0Bh	0Ch	0Dh	0Eh	0Fh
80h	Ъ	Ѓ	,	ѓ	„	…	†	‡	€	‰	Љ	‹	Њ	Ќ	Ў	Ѓ
90h	ђ	‘	’	“	”	•	–	—		™	љ	›	њ	ќ	ћ	џ
A0h		Ў	џ	Ј	α	Ѓ	ı	§	Ë	©	Є	«	¬	-	®	Ѓ
B0h	°	±	ı	ı	ѓ	μ	¶	·	ё	№	є	»	ј	ѕ	ѕ	ї
C0h	А	Б	В	Г	Д	Е	Ж	З	И	Й	К	Л	М	Н	О	П
D0h	Р	С	Т	У	Ф	Х	Ц	Ч	Ш	Щ	Ъ	Ы	Ь	Э	Ю	Я
E0h	а	б	в	г	д	е	ж	з	и	й	к	л	м	н	о	п
F0h	р	с	т	у	ф	х	ц	ч	ш	щ	ъ	ы	ь	э	ю	я

Windows-1252 (West European Latin)

	00h	01h	02h	03h	04h	05h	06h	07h	08h	09h	0Ah	0Bh	0Ch	0Dh	0Eh	0Fh
80h	€		,	f	„	…	†	‡	^	‰	Š	<	Œ		Ž	
90h		‘	’	“	”	•	–	—	~	™	š	>	œ		ž	ÿ
A0h		ı	ç	£	¤	¥	ı	§	¨	©	ª	«	¬	-	®	¯
B0h	°	±	²	³	´	µ	¶	·	¸	¹	º	»	¼	½	¾	¿
C0h	À	Á	Â	Ã	Ä	Å	Æ	Ç	È	É	Ê	Ë	Ì	Í	Î	Ï
D0h	Ð	Ñ	Ò	Ó	Ô	Õ	Ö	×	Ø	Ù	Ú	Û	Ü	Ý	Þ	ß
E0h	à	á	â	ã	ä	å	æ	ç	è	é	ê	ë	ì	í	î	ï
F0h	ð	ñ	ò	ó	ô	õ	ö	÷	ø	ù	ú	û	ü	ý	þ	ÿ

Windows-1253 (Greek)

	00h	01h	02h	03h	04h	05h	06h	07h	08h	09h	0Ah	0Bh	0Ch	0Dh	0Eh	0Fh
80h	€		,	f	„	…	†	‡		‰		<				
90h		‘	’	“	”	•	–	—		™		>				
A0h		“	À	£	¤	¥	ı	§	¨	©		«	¬	-	®	¯
B0h	°	±	²	³	´	µ	¶	·	¸	¹	º	»	¼	½	¾	¿
C0h	ı	Α	Β	Γ	Δ	Ε	Ζ	Η	Θ	Ι	Κ	Λ	Μ	Ν	Ξ	Ο
D0h	Π	Ρ		Σ	Τ	Υ	Φ	Χ	Ψ	Ω	ı	ÿ	ά	έ	ή	ί
E0h	ÿ	α	β	γ	δ	ε	ζ	η	θ	ι	κ	λ	μ	ν	ξ	ο
F0h	π	ρ	ς	σ	τ	υ	φ	χ	ψ	ω	ı	ÿ	ό	ύ	ώ	

□

Windows-1255 (Hebrew)

	00h	01h	02h	03h	04h	05h	06h	07h	08h	09h	0Ah	0Bh	0Ch	0Dh	0Eh	0Fh
80h	€		,	f	„	…	†	‡	^	‰		<				
90h		‘	’	“	”	•	–	—	~	™		>				
A0h		ı	ç	£	¤	¥	ı	§	¨	©	×	«	¬	-	®	¯
B0h	°	±	²	³	´	µ	¶	·	¸	¹	÷	»	¼	½	¾	¿
C0h	ı	“	“	“	“	“	“	“	“	“	“	“	“	“	“	“
D0h		·	·	:		ıı	“	’	”	,	:	;	.	!	?	
E0h	א	ב	ג	ד	ה	ו	ז	ח	ט	י	ך	כ	ל	ד	מ	ן
F0h	ס	ע	פ	צ	ק	ר	ש	ת								

Windows-1257 (Baltic)

	00h	01h	02h	03h	04h	05h	06h	07h	08h	09h	0Ah	0Bh	0Ch	0Dh	0Eh	0Fh
80h	€		,		„	…	†	‡		‰		<		“	”	ˆ
90h		‘	’	“	”	•	–	—		™		>		—		˘
A0h			¢	£	¤		¦	§	Ø	©	Ŕ	«	¬	-	®	Æ
B0h	°	±	²	³	´	µ	¶	·	ø	¹	ŗ	»	¼	½	¾	æ
C0h	Ą	Į	Ā	Ć	Ä	Å	Ę	Ē	Č	É	Ž	Ė	Ġ	Ķ	Ī	Ļ
D0h	Š	Ņ	Ņ	Ó	Ō	Õ	Ö	×	Ū	Ł	Ś	Ū	Ü	Ž	Ž	ß
E0h	ą	į	ā	ć	ä	å	ę	ē	č	é	ž	ė	ġ	ķ	ī	ļ
F0h	š	ņ	ņ	ó	ō	õ	ö	÷	ū	ł	ś	ū	ü	ž	ž	·

Windows-1254 (Turkish)

	00h	01h	02h	03h	04h	05h	06h	07h	08h	09h	0Ah	0Bh	0Ch	0Dh	0Eh	0Fh
80h	€		,	f	„	…	†	‡	^	‰	Š	<	Œ			
90h		‘	’	“	”	•	–	—	~	™	š	>	œ			ÿ
A0h		ı	¢	£	¤	¥	¦	§	¨	©	ª	«	¬	-	®	¯
B0h	°	±	²	³	´	µ	¶	·	¸	¹	º	»	¼	½	¾	¿
C0h	À	Á	Â	Ã	Ä	Å	Æ	Ç	È	É	Ê	Ë	Ì	Í	Î	Ï
D0h	Ğ	Ñ	Ò	Ó	Ô	Õ	Ö	×	Ø	Ù	Ú	Û	Ü	İ	Ş	ß
E0h	à	á	â	ã	ä	å	æ	ç	è	é	ê	ë	ì	í	î	ï
F0h	ğ	ñ	ò	ó	ô	õ	ö	÷	ø	ù	ú	û	ü	ı	ş	ÿ

Arabic Unicode 0x0600 ~ 0x06FF

ا	س	م	ص	سم		٣	٤	و	٪	٪	ف	،	،	م	ع
0600	0601	0602	0603	0604	0605	0606	0607	0608	0609	060A	060B	060C	060D	060E	060F
ص	ع	ح	ض	س	ط	ل	ز	ر	ء		؛			ي	؟
0610	0611	0612	0613	0614	0615	0616	0617	0618	0619	061A	061B	061C	061D	061E	061F
ي	ء	آ	أ	ؤ	إ	ئ	ا	ب	ة	ت	ث	ج	ح	خ	د
0620	0621	0622	0623	0624	0625	0626	0627	0628	0629	062A	062B	062C	062D	062E	062F
ذ	ر	ز	س	ش	ص	ض	ط	ظ	ع	غ	ك	ك	ي	تي	ثي
0630	0631	0632	0633	0634	0635	0636	0637	0638	0639	063A	063B	063C	063D	063E	063F
-	ف	ق	ك	ل	م	ن	ه	و	ي	ي	؁	ئ		ـ	ـ
0640	0641	0642	0643	0644	0645	0646	0647	0648	0649	064A	064B	064C	064D	064E	064F
ـ	ء	هـ	ـ	ء	ء	ا	،	ـ	-	٧	٨		٩	٠	١
0650	0651	0652	0653	0654	0655	0656	0657	0658	0659	065A	065B	065C	065D	065E	065F
٠	١	٢	٣	٤	٥	٦	٧	٨	٩	٪	ر	،	★	س	و
0660	0661	0662	0663	0664	0665	0666	0667	0668	0669	066A	066B	066C	066D	066E	066F
ا	أ	أ	إ	ء	أ	ؤ	ؤ	ئ	ئ	ن	ت	ت	ت	پ	ت
0670	0671	0672	0673	0674	0675	0676	0677	0678	0679	067A	067B	067C	067D	067E	067F
پ	خ	خ	ج	ج	خ	ج	ج	د	د	د	د	ت	د	د	د
0680	0681	0682	0683	0684	0685	0686	0687	0688	0689	068A	068B	068C	068D	068E	068F
ظ	ر	ر	ر	ر	ر	ر	ر	ر	ر	ر	ر	ر	ر	ر	ر
0690	0691	0692	0693	0694	0695	0696	0697	0698	0699	069A	069B	069C	069D	069E	069F
ش	ف	ف	ف	ف	ف	ف	ف	ك	ك	ك	ك	ك	ك	ك	ك
06A0	06A1	06A2	06A3	06A4	06A5	06A6	06A7	06A8	06A9	06AA	06AB	06AC	06AD	06AE	06AF
گ	گ	گ	گ	گ	ل	ل	ل	ل	ن	ن	ن	ن	ن	ن	ن
06B0	06B1	06B2	06B3	06B4	06B5	06B6	06B7	06B8	06B9	06BA	06BB	06BC	06BD	06BE	06BF
هـ	هـ	هـ	هـ	هـ	هـ	هـ	هـ	هـ	هـ	هـ	هـ	هـ	هـ	هـ	هـ
06C0	06C1	06C2	06C3	06C4	06C5	06C6	06C7	06C8	06C9	06CA	06CB	06CC	06CD	06CE	06CF
پ	پ	پ	پ	-	هـ	ط	ط	م	لا	ج	ء	س	س	س	هـ
06D0	06D1	06D2	06D3	06D4	06D5	06D6	06D7	06D8	06D9	06DA	06DB	06DC	06DD	06DE	06DF
٠	١	٢	٣	٤	٥	٦	٧	٨	٩	بش	ض	غ	ء	م	هـ
06E0	06E1	06E2	06E3	06E4	06E5	06E6	06E7	06E8	06E9	06EA	06EB	06EC	06ED	06EE	06EF
٠	١	٢	٣	٤	٥	٦	٧	٨	٩	بش	ض	غ	ء	م	هـ
06F0	06F1	06F2	06F3	06F4	06F5	06F6	06F7	06F8	06F9	06FA	06FB	06FC	06FD	06FE	06FF

Appendix A: Command Details

A.1. Overwrite mode

In this mode, the cursor will move towards the right and begin from the upper left position. When the cursor has reached the end of the upper line, the cursor will move down to the bottom left position to continue. When the cursor has reached the end of the bottom line, it will move to up the upper left position and overwrite the previous characters.

A.2. Vertical scroll mode

In this mode, the cursor will move towards the right. The cursor will begin from the upper left position until it has reached the end of the upper line. The cursor will then move down to the bottom left position to continue until it has reached the end of the bottom line.

A.3. Horizontal scroll mode

In this mode, the extent of the cursor activity is bound by a predefined range, limited to the upper line. (Please refer to Set or cancel window command), where the default window is the whole upper line. The cursor will begin from the left-end of the range and move rightward until it reached the end of the range, to continue, the characters that comes thereafter will start pushing the previous characters leftward from the right-end, scrolling the characters to the left.

A.4. Set the string display mode and write string to display

Set the string display mode, write to upper or lower line $d1\ d2\ d3\ \dots\ dn$ $\{1 \leq n \leq 20\}$. 'A' stands for the upper line, 'B' stands for the lower line. The string display mode will be cancelled and the display will return to the previous mode after receiving CLR or CAN.

A.5. Upper line message continuous scroll

The message (previously defined) will scroll continuously in the horizontal direction until a new command is received.

A.6. Move cursor left

When the current cursor is at the left-end position, this command operates differently depending on the display mode.

- **Overwrite mode:** When the cursor reached the left-end of the lower line, it will continue to the right-end of the upper line, overwrite previous characters. When it reached the left end of the upper line, it will continue to the right-end of the lower line.
- **Vertical scroll mode:** When the cursor reached the left-end of the lower line, the lower line will scroll up and replace the previous upper line, the lower line will be cleared and the cursor will continue to the right end of the lower line.
- **Horizontal scroll mode:** The cursor will remain stationary.

A.7. Move cursor right

Move the cursor to the right. When the cursor has reached the right-end, this command operates differently depending on the display mode.

- **Overwrite mode:** When the cursor has reached the right-end of the lower line, it will continue to the left-end of the upper line and overwrite previous characters. When it has reached the right-end of the upper line, it will continue to the right-end of the lower line.
- **Vertical scroll mode:** When the cursor has reached the right-end of the lower line, the lower line will scroll up to replace the upper line, the lower line is cleared and ready to continue characters thereafter.
- **Horizontal scroll mode:** The cursor will remain stationary.

A.8. Move cursor up

Move the cursor up one line. When the cursor is on the upper line, this command operates differently depending on the display mode.

- **Overwrite mode:** The cursor is moved to the same column the lower line.
- **Vertical scroll mode:** The characters displayed on the upper line is scrolled to the lower line, and the upper line is cleared. The cursor will remain at the same position.
- **Horizontal scroll mode:** The cursor will remain stationary.

A.9. Move cursor down

Move the cursor down one line. When the cursor is on the lower line, this command operates differently depending on the display mode.

- **Overwrite mode:** The cursor is moved to the same column on the upper line.
- **Vertical scroll mode:** The characters displayed on the lower line are scrolled to the upper line, and the lower line is cleared. The cursor will remain at the same position.
- **Horizontal scroll mode:** The cursor will remain stationary.

A.10. Move cursor to home position

The cursor will move to the left-end position of the upper line.

A.11. Move cursor to left-most position

The cursor will be moved to the left-end position of the current line.

A.12. Move cursor to right-most position

The cursor will be moved to the right-end position of the current line.

A.13. Move cursor to bottom position

The cursor will be moved to the right-end position on the lower line.

A.14. Move cursor to specified position

The cursor will be moved to column x on line y.

A.15. Initialize display

The data in the input buffer will be cleared and reset from default.

A.16. Reset the window

Reset the window on the display.

When s=0, the window is cancelled (values: x1, x2, and y are not required.)

When s=1, the window will be reset (values: x1, x2, and y are required.)

The x1 and x2 set the position of the left column and right column, respectively, of the window.

The y sets the upper line or the lower line of the window.

This function is valid within the horizontal mode.

A.17. Clear display screen and clear string mode

All the display characters will be cleared, and the string mode will be cancelled.

A.18. Clear current line and cancel string mode

The current line is cleared, and the string mode is cancelled.

A.20. Set cursor ON or OFF

When n=0, cursor is OFF

When n=1, cursor is ON

Appendix B: Control Code Set

HEX	CODE	HEX	CODE
00H	NULL	10H	DLE
01H	SOH, MD1	11H	DC1
02H	STX, MD2	12H	DC2
03H	ETX, MD3	13H	DC3
04H	EOT, MD4	14H	DC4
05H	ENQ, MD5	15H	NAK
06H	ACK, MD6	16H	SYN
07H	BEL, MD7	17H	ETB
08H	BS, MD8	18H	CAN
09H	HT	19H	EM
0AH	LF	1AH	SUB
0BH	VT, HOM	1BH	ESC
0CH	FF, CLR	1CH	FS
0DH	CR	1DH	GS
0EH	SO, SLE1	1EH	RS, SF1
0FH	SI, SLE2	1FH	US, SF2